

innovative, long-lasting & attractive

DISPENSERS

for fixed and mobile grocery shops

APPLYVRAC®

eterniti®

*designed
for life!*

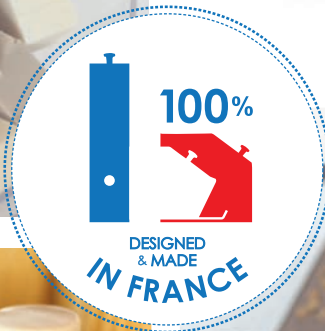
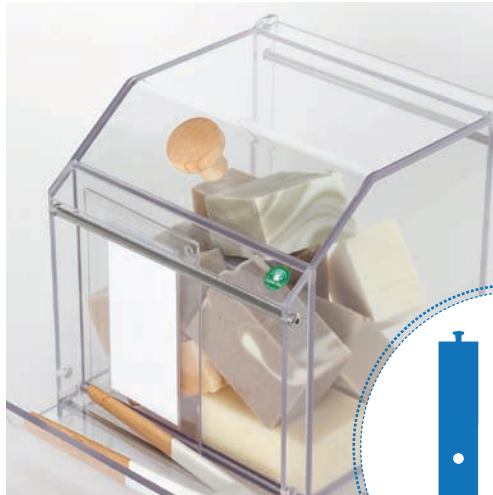

The pleasure of bulk goods every day™

Registered trademarks and designs

Contents

The APPLYVRAC® Eterniti® range	p.3
General presentation	p.3
Main characteristics of the dispensers	p.4
The different models	p.5
Gravity dispensers	p.5
Scoop dispensers	p.7
Small display cases	p.9
Large display cases with lid	p.10
Large display cases without lid	p.12
Oil and liquid dispensers	p.14
Honey dispensers	p.16
Accessories	p.18
Some installation examples	p.19
About APPLYMAGE®	p.20

The APPLYVRAC® Eterniti® range

How did it come about?

The **APPLYVRAC® Eterniti®** range grew out of meetings and exchanges with various responsible trade stakeholders who were on the lookout for **practical, long-lasting, attractive containers** which are also fun to use.

What does it include?

The **APPLYVRAC® Eterniti®** range is made up of eco-designed gravity dispensers, scoop dispensers, display cases and specific dispensers, and is constantly evolving to adapt to the **changing needs of retailers and convenience shops**: organic and bulk grocery shops, local alternative grocery shops and local producers.

Where and how are the products made?

The products in the **APPLYVRAC® Eterniti®** range are **entirely designed and manufactured in France**, in the Lyon region, using the **best conventional machining** techniques and a **short supply chain** and local economy approach.

Which requirements do the products meet?

The materials used to make the products in the **APPLYVRAC® Eterniti®** range are of the highest quality and are naturally **recyclable**. They are approved for contact with food and free from both BPA and phthalates. These physiologically safe **materials** are all **certified according to the standards in force and the latest food regulations** (analyses and tests carried out by several independent French and foreign laboratories).

Who are the products intended for?

Thanks to their specific characteristics, **APPLYVRAC® Eterniti®** dispensers are a **real alternative** to other products on the market. That's why they have already been chosen by **numerous (fixed and mobile) shops** and other **Zero Waste** proponents in France and abroad.

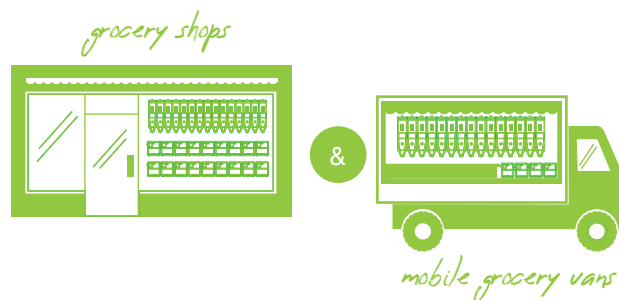

Main characteristics

OF THE DISPENSERS

APPLYVRAC®
eterniti®

→ Clean lines for total transparency

- design combining **simplicity, aesthetics and functionality**
- **excellent product visibility** to **showcase items in a neat and original way**
- **easy to use** for customers
- Instant **visual control** helps shopkeepers to:
 - monitor stocks in real time
 - step up the prevention of health risks

→ Installation efficiency and freedom

- **less space taken up** in aisles
- **wide choice of volumes and models** adapted to the products and their shelf lives
- **installation possible on all kinds of furniture:**
 - numerous installation solutions (from kitchen dressers to custom furniture)
 - several attachment methods available (very handy for mobile grocery vans)

→ Ergonomic and intuitive to use

- **control** and pleasure of **self-service**
 - flap that opens gradually and bag-holder on gravity dispensers
 - reduced waste thanks to the gravity dispensers' safety lock
 - lid that slides downwards on scoop dispensers
- **perfect stability:**
 - safety during handling
- **easy to fill**
- **optimum balance** between dimensions, weights and volumes:
 - reduction in expenses and prevention of musculo-skeletal disorders

→ Enhanced hygiene

- **easy cleaning** and maintenance:
 - many parts are removable or extractable (including the gravity dispenser spout for regular and rapid cleaning)
 - dispensers are lightweight and sturdy, so they can be cleaned manually with vigour
 - can be placed in professional dishwashers
- **excellent airtightness:**
 - gravity dispensers have a lock and dual-flap system, which helps to reduce health risks
 - scoop dispensers have airtight lids
- **contact area restricted to release knobs** during service:
 - knobs are treated against germs, bacteria, viruses and coronaviruses (including Covid-19)
 - scoop dispensers can be opened without touching the inside of the lid

→ Exceptional durability

- The materials used are of **top quality** and **extremely impact-resistant**
 - they are guaranteed to be sturdy and last an extremely long time
- **Extended life span** of the products:
 - total, simple and fast repairability
 - all components can be replaced by the user
 - assembly is fully mechanical with stainless steel crosspieces (no gluing or welding) and there are no plastic injection-moulded parts
 - reduction in waste as well as logistical and transport constraints (reduced carbon footprint)
- **5-year contractual warranty**

→ Possibility of customisation and tailor-made items

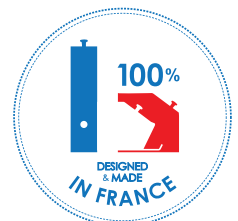

GRAVITY DISPENSERS

What products are they suitable for?

Small, non-powdery, non-sticky, non-liquid, packaging-free products*

* Gravity dispensers are not suitable for all kinds of products: please refer to the "contents/containers" list provided.

Thanks to their gentle and gradual **DUAL-FLAP** system, APPLYVRAC® Eterniti® gravity dispensers **DISPENSE JUST THE RIGHT AMOUNT** and offer **GREAT VISIBILITY**.

The safety lock reduces waste and health risks.

The bag-holder makes it easier for customers to fill up their bags.

The extractable parts (lid, front panel, flap, spout and bag-holder) ensure **EFFECTIVE CLEANING**.

Several attachment methods are available for greater installation efficiency and freedom.

This handy solution is particularly popular in mobile grocery vans.

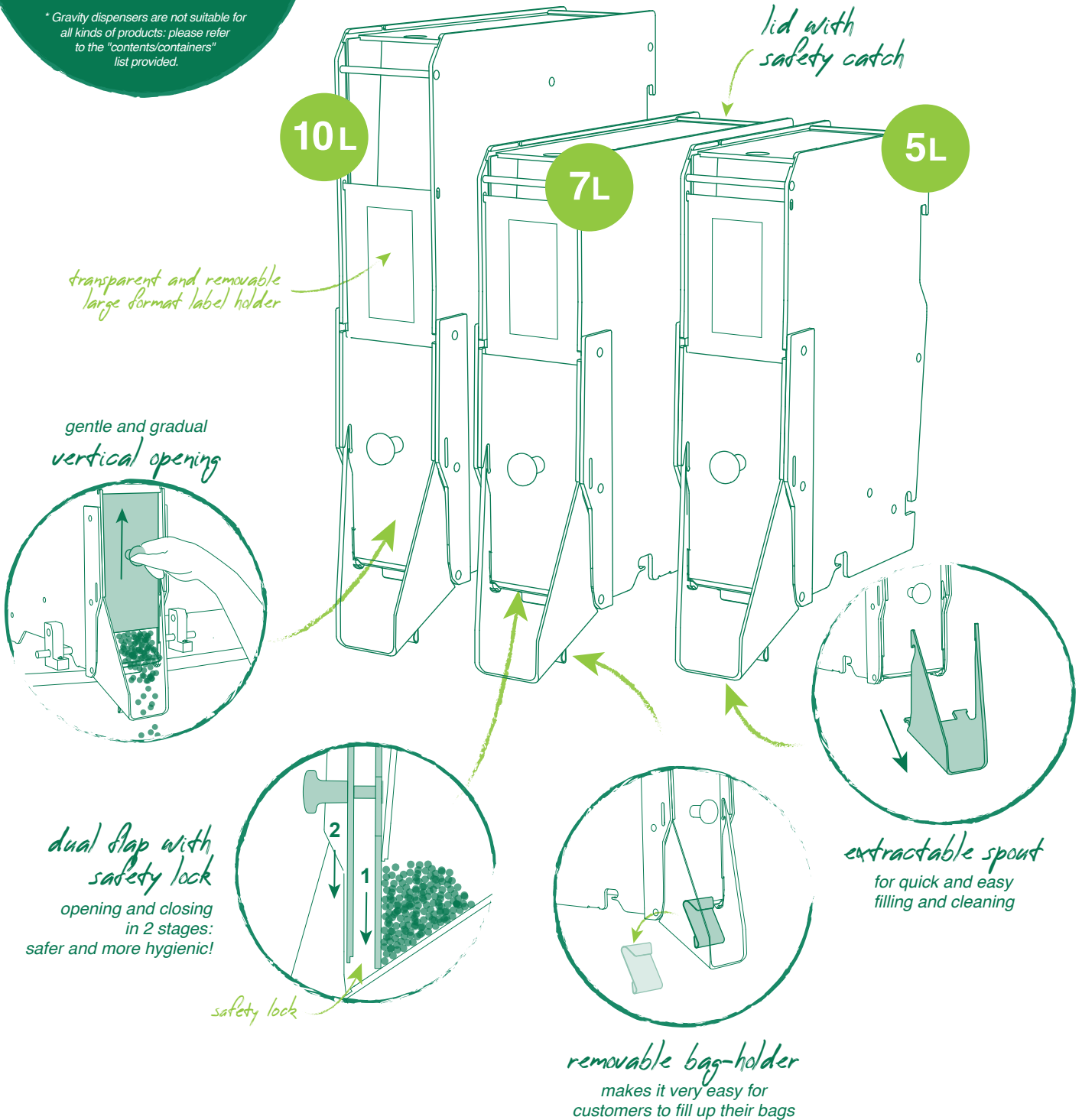

FOR SPECIFIC GRAVITY DISPENSER ACCESSORIES: see p. 18



completely transparent for excellent product visibility and promotion



dual-flap system for safe service



extractable spout & removable bag holder



very easy to clean

• dimensions

5L overall: 120 (w.) x 457 (h.) x 300 (d.) ⁽¹⁾
(excl. spout: 120 (w.) x 395 (h.) x 278 (d.))

7L overall: 120 (w.) x 457 (h.) x 400 (d.) ⁽²⁾
(excl. spout: 120 (w.) x 395 (h.) x 378 (d.))

10L overall: 120 (w.) x 552 (h.) x 400 (d.) ⁽²⁾
(excl. spout: 120 (w.) x 490 (h.) x 378 (d.))

⁽¹⁾ : min. depth of the furniture unit or shelf: 219 mm

⁽²⁾ : min. depth of the furniture unit or shelf: 319 mm

• materials 

Food-grade recyclable PET-G (without Bisphenol A), silicone and stainless steel, solid wood (PEFC)

• weight

5L: approx. 2.1 kg

7L: approx. 2.4 kg

10L: approx. 2.9 kg



Extended life span



Total reparability



Less space taken up in aisles



Knobs treated against germs

SCOOP DISPENSERS

What products are they suitable for?

Products of all sizes, including powdery and floury, complex-shaped and non-liquid products.

The extremely **AIRTIGHT** and **INCREDIBLY VERSATILE** APPLYVRAC® Eterniti® scoop dispensers can be used for all kinds of food or non-food products. Their extractable scoop holder, top hatch and lid make them **EASY TO FILL** and **CLEAN**.

Thanks to its optimum "space-to-volume" ratio and its wide opening, 20L and 30L dispensers are ideal for **VERY HIGH TURNOVER PRODUCTS** (pasta, sugar, flour, sodium bicarbonate, animal food, etc.)

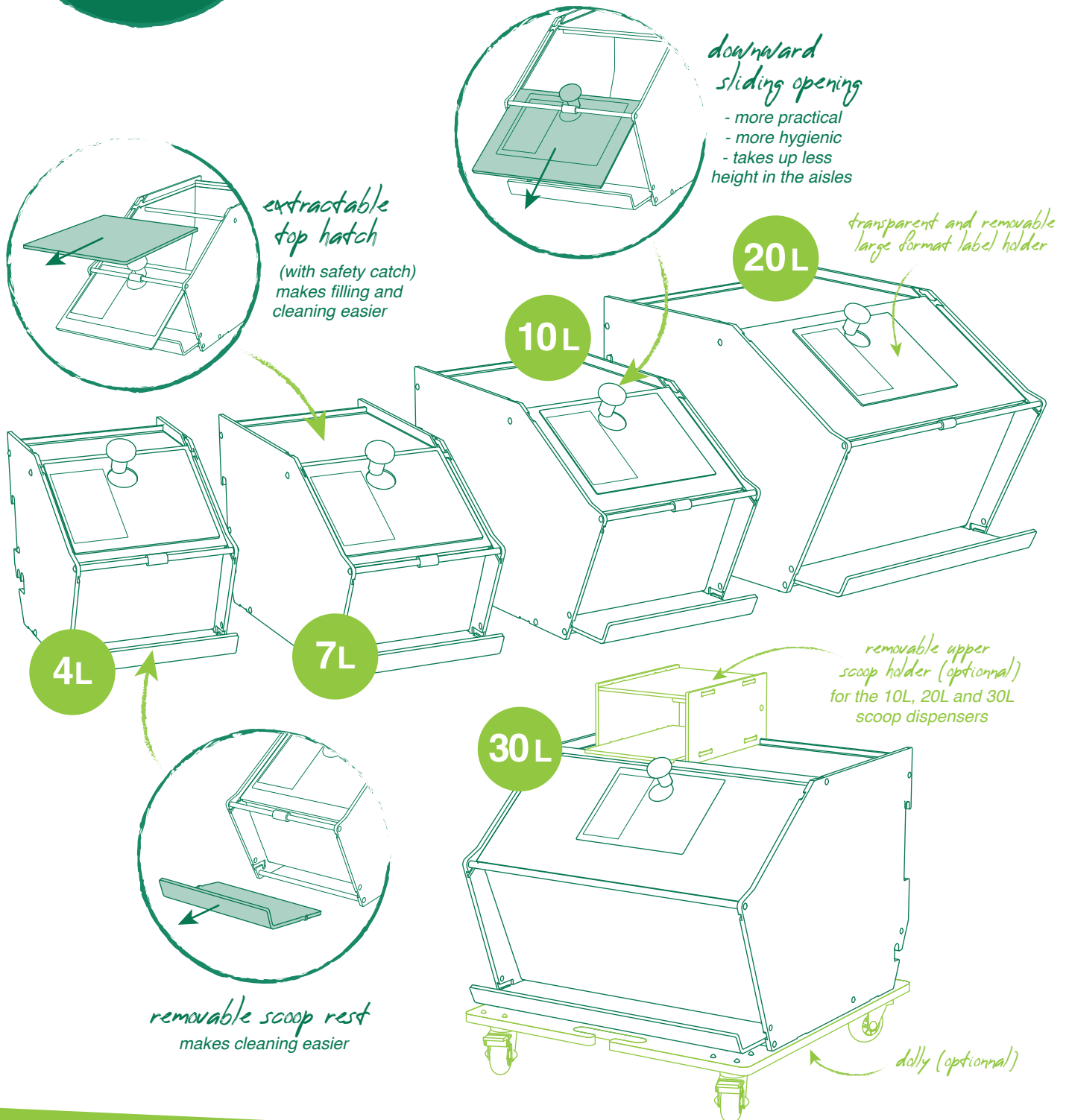

completely transparent for excellent product visibility and promotion



downward sliding openings:
more practical, more hygienic

dolly tailored to the 30L model (optional)



very easy to clean



• dimensions

- 4L: 170 (w.) x 217 (h.) x 270 (d.)
- 7L: 170 (w.) x 217 (h.) x 375 (d.)
- 10L: 200 (w.) x 250 (h.) x 385 (d.)
- 20L: 316 (w.) x 293 (h.) x 400 (d.)
- 30L: 392 (w.) x 315 (h.) x 415 (d.)

• materials 

Food-grade recyclable PET-G (without Bisphenol A), silicone and stainless steel, solid wood (PEFC)

• weight

- 4L: approx. 1.2 kg
- 7L: approx. 1.6 kg
- 10L: approx. 2 kg
- 20L: approx. 3.6 kg
- 30L: approx. 5.4 kg
(dolly: approx. 2.1 kg)



Extended life span



Total reparability



Optimum airtightness



Knobs treated against germs

SMALL DISPLAY CASE

What products are they suitable for?
ideal for top picks!

The 3L APPLYVRAC® Eterniti® display case is ideal for presenting and housing **LOSS LEADERS**, **'TOP PICKS'** or **VALUABLE PRODUCTS**.
As it **DOES NOT TAKE UP MUCH SPACE**, it can be placed anywhere, including in prime positions in sales areas.
With its removable lid, front panel and scoop rest, it is quick and easy to look after.

rapid and simple maintenance

thanks to removable lid, front panel and scoop rest

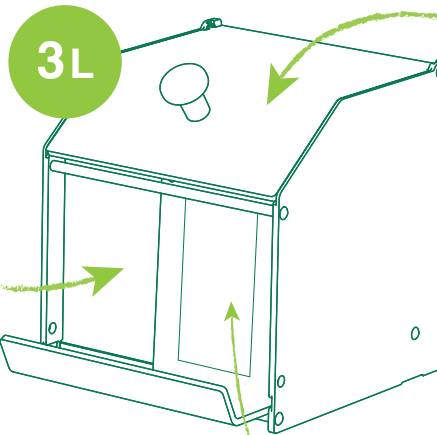
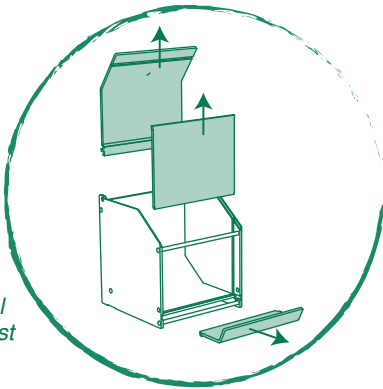

3L

transparent and removable label holder

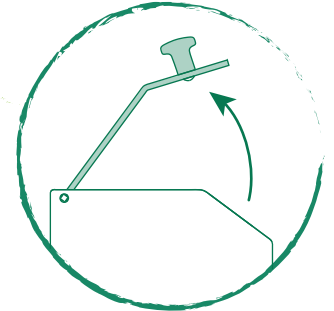

hinged lid

- very large opening
- extractable



optimum accessibility



very easy to clean

• dimensions

170 (w.) x 196 (h.) x 215 (d.)

• materials

Food-grade recyclable PET-G (without Bisphenol A), silicone and stainless steel, solid wood (PEFC)

• weight

approx. 0.9 kg



Extended life span



Total reparability



Lightweight



Ideal for festive periods



Knobs treated against germs

LARGE DISPLAY CASE

WITH LID

Thanks to their shape and modular nature, the APPLYVRAC® Eterniti® large display cases can be used for products which require **SPECIAL PRESENTATION** and can't be placed in gravity or scoop dispensers (chocolate bars, cosmetics or hygiene products, etc.) and/or **LOSS LEADERS** or valuable items.
Their removable tongs rest and lid make them particularly **EASY to USE** and **MAINTAIN**.

CLASSIC MODEL

WITHOUT PODIUMS

What products are they suitable for?

non-crumblly,
non-powdery
and residue-free
products

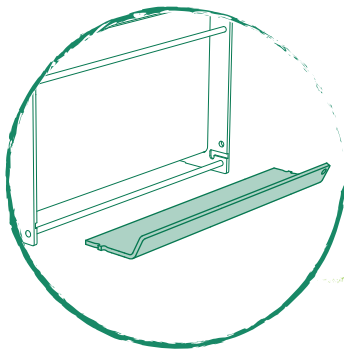

*removable tongs rest
makes cleaning easier*

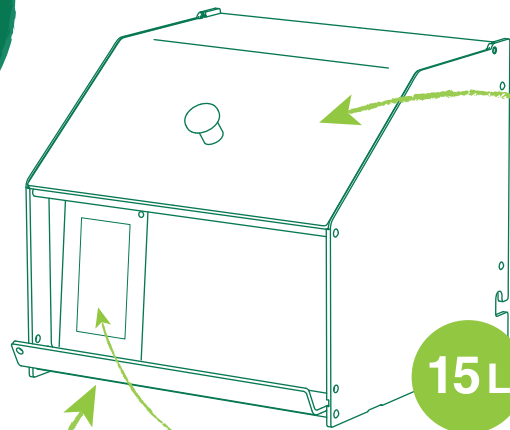

15L

*transparent and
removable label holder
(additional copies on request)*

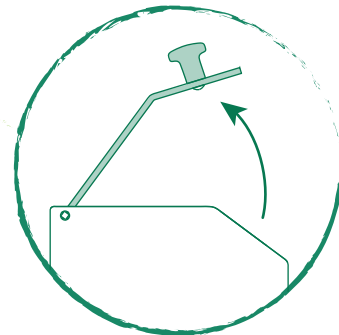

hinged lid

- very large opening
- extractable

MODEL A

WITH PODIUMS AND COMPARTMENTS

What products are they suitable for?

ideal for
chocolate bars
or cosmetics!

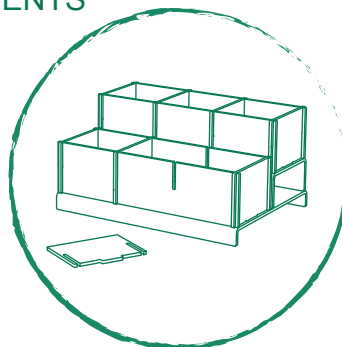

modular podiums

- 2 to 6 compartments
- removable and fully
detachable

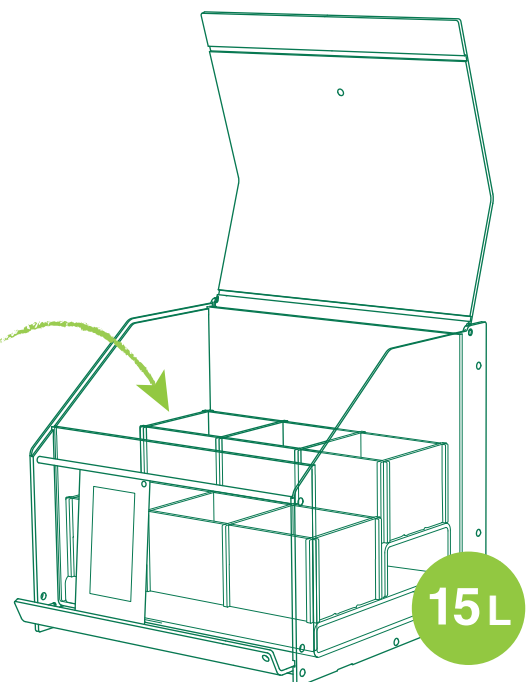

15L

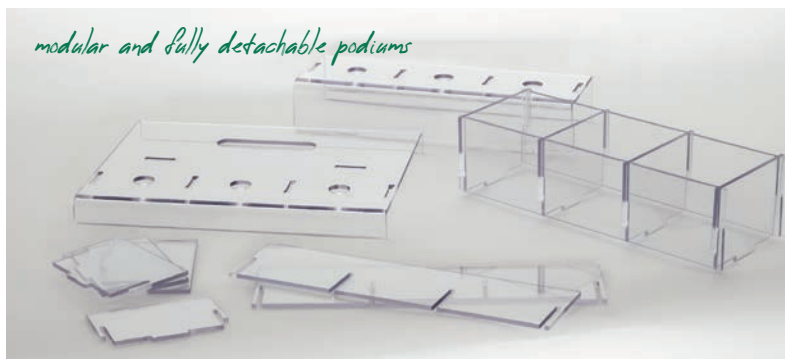

• dimensions

overall: 312 (w.) x 281 (h.) x 327 (d.)
compartments (inside): 90 (w.) x 75 (h.) x 89 (d.)

• materials 

Food-grade recyclable PET-G (without Bisphenol A), stainless steel, solid wood (PEFC)

• capacity

model A:

- 36 to 60 chocolate bars (depending on thickness)
- cosmetics, hygiene or other products: variable depending on the products displayed

• weight

classic model: approx. 2.6 kg
model A: approx. 3.9 kg



Extended life span



Total reparability



Great modularity



Knobs treated against germs

LARGE DISPLAY CASE

WITHOUT LID

The APPLYVRAC® Eterniti® display cases without lid are **WIDELY ACCESSIBLE** and can therefore display products with very specific and very different shapes that can't be placed in conventional dispensers or containers.

What products are they suitable for?

non-crumbly,
non-powdery
and residue-free
products

CLASSIC MODEL

WITHOUT PODIUMS

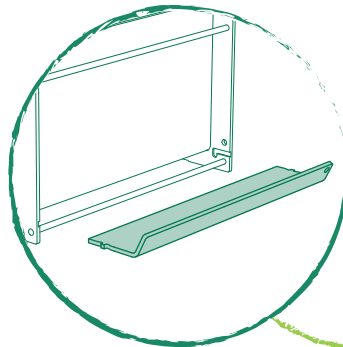

*removable tongue rest
makes cleaning easier*

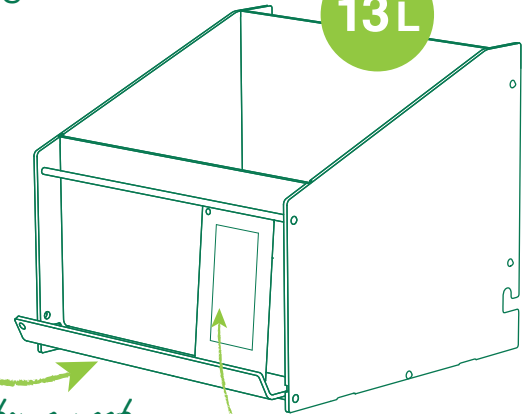

13L

*transparent and
removable label holder
(additional copies on request)*

MODEL C

WITH PODIUMS AND LARGE BOTTLES

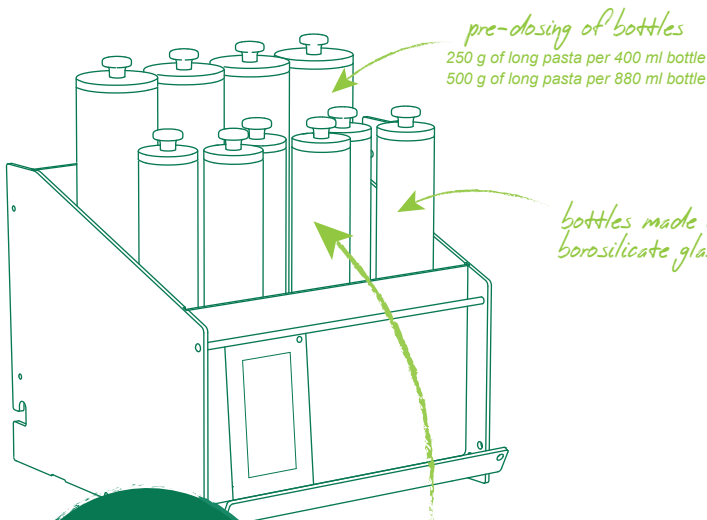

*pre-closing of bottles
250 g of long pasta per 400 ml bottle
500 g of long pasta per 880 ml bottle*

*bottles made of
borosilicate glass*

MODEL D

WITH PODIUMS AND SMALL BOTTLES

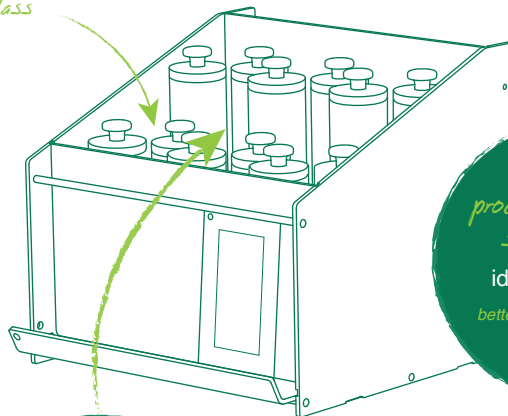

What products are they suitable for?

ideal for spices!

*better space to number of
references ratio*

What products are they suitable for?

ideal for long pasta!

*modular
bottles and podiums*

- excellent airtightness
- easy and quick to clean

modular bottles and podiums

- excellent airtightness
- easy and quick to clean

3 possible configurations

- 12 x 230 ml bottles
- 4 x 500 ml bottles + 6 x 230 ml bottles
- 8 x 500 ml bottles



modular bottles and podiums



classic model



model C with 4 x 880 ml bottles
and 6 x 500 ml bottles



model D with 12 x 230 ml bottles



model D with 4 x 500 ml bottles
and 6 x 230 ml bottles



model D with 8 x 500 ml bottles



• dimensions

classic model: 312 (w.) x 275 (h.) x 327 (d.)

model C: 312 (w.) x 378 (h.) x 327 (d.)

model D: 312 (w.) x 275 (h.) x 327 (d.)

• materials 

Food-grade recyclable PET-G (without Bisphenol A), borosilicate glass, stainless steel and silicone, solid wood (PEFC)

• capacity

model C: 4 x 880 ml bottles + 6 x 400 ml bottles

model D (3 possible configurations):

- 12 x 230 ml bottles
- 4 x 500 ml bottles + 6 x 230 ml bottles
- 8 x 500 ml bottles

• poids

classic model: approx. 2.2 kg

model C: approx. 5.8 kg

model D: approx. 4.6 kg



Extended life span



Total reparability



Perfectly airtight bottles



Knobs treated against germs

OIL AND LIQUID DISPENSERS

What products are they suitable for?

ideal for vegetable oils!

APPLYVRAC® Eterniti® oil and liquid dispensers are designed to ensure **CLEAN AND SAFE SERVICE** thanks to their precision tap and their removable tray.

The **EMPTYING SYSTEM** ensures that every last drop of the liquid is recovered; it also makes the dispenser easier to clean.

And as these dispensers are totally transparent they are ideal for promoting the product on sale.

lid with safety catch

10L

6L

3L

overflow prevention zone
makes the product less likely to overflow when handling the 6L and 10L dispensers

transparent and removable large format label holder

easy and thorough cleaning
- detachable tap with equipment provided
- removable tray

easy and clean service
- self-service
- stainless steel tap with locking system
- removable tray

emptying system
- ensures that every last drop is recovered
- makes cleaning easier

ACCESSORIES

OPACIFYING PLATES
(optional)

2 removable plywood side plates and 1 removable plywood top plate:
to further protect oil against UV rays

choice between 3 volumes
(3L, 6L and 10L)



very easy to clean



great product promotion



easy and clean
service

with opacifying plates
(optional)



• dimensions

- model 3L: 116 (w.) x 310 (h.) x 310 (d.)¹
- model 6L: 116 (w.) x 395 (h.) x 388 (d.)²
- model 10L: 144 (w.) x 490 (h.) x 388 (d.)²

¹: min. depth of the furniture unit or shelf: 244 mm
²: min. depth of the furniture unit or shelf: 319 mm

• materials 

Food-grade recyclable PET-G (without Bisphenol A), stainless steel and silicone
Opacifying plates : plywood

• weight

- model 3L: approx. 2.3 kg
- model 6L: approx. 3.3 kg
- model 10L: approx. 4.3 kg



Extended life span



Total reparability



No leftover residue



Easy to clean

HONEY DISPENSER

What products are they suitable for?

ideal for liquid honey!

such as: acacia, alder buckthorn, chestnut, oak, summer flowers, forest, alfafa, mountain, orange blossom, blackberry, fir and lime blossom, etc.

The APPLYVRAC® Eterniti® honey dispenser is designed to ensure **CLEAN AND SAFE SERVICE** thanks to their precision tap (patented) and their removable pot-holder. The **EMPTYING SYSTEM** ensures that every last drop of the liquid is recovered; it also makes the dispenser easier to clean.

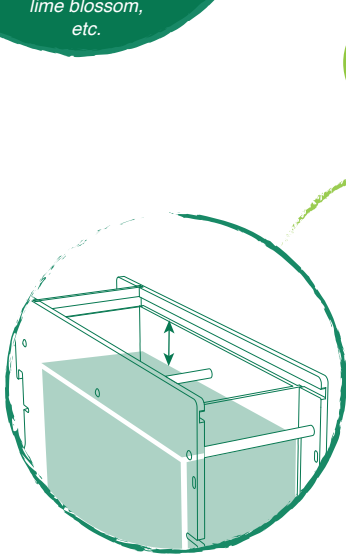

overflow prevention zone
makes the product less likely to overflow when handling the dispenser

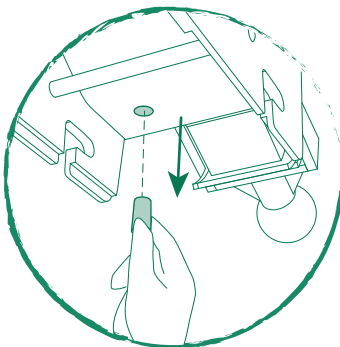

emptying system
- ensures that every last drop is recovered
- makes cleaning easier

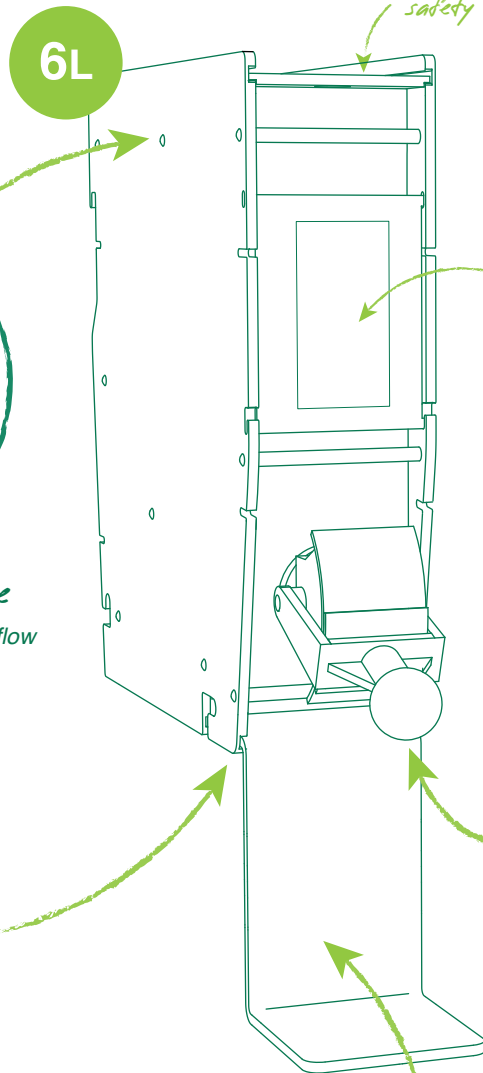

lid with safety catch

transparent and removable large format label holder

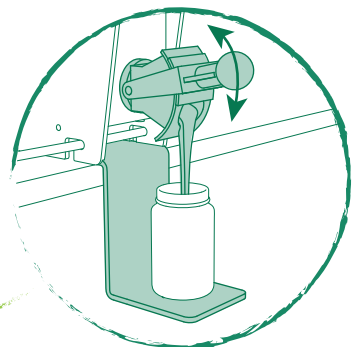

easy and clean service
- self-service
- non-drip honey tap with adjustable flow (patented)
- pot-rest tray

easy and thorough cleaning
- detachable tap with equipment provided
- removable pot rest

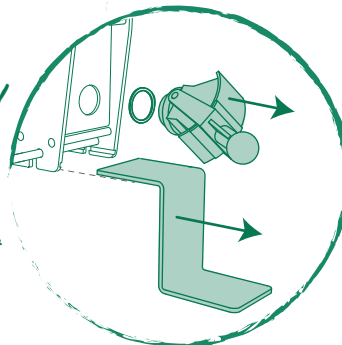



extremely effective non-drip tap

pot rest for safe and convenient service



very easy to clean



tightening wrenches to install the tap

• *dimensions*

- without tray: 116 (w.) x 395 (h.) x 478 (d.)*
- with tray: 116 (w.) x 550 (h.) x 478 (d.)*

* : min. depth of the furniture unit or shelf: 319 mm

• *materials* 🍷

Food-grade recyclable PET-G (without Bisphenol A), polyamide and silicone

• *weight*

approx. 3.3 kg



Extended life span



Total reparability



No leftover residue



Easy to clean

ATTACHMENT KIT

unique attachment* system for all APPLYVRAC® Eterniti® dispensers

- *material*
PEFC plywood

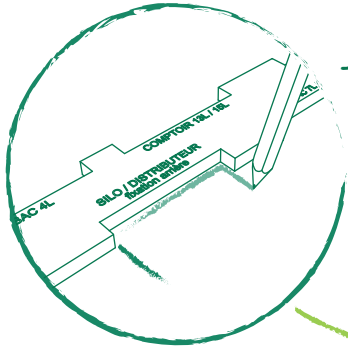

set square

- defines the position of the L brackets
- ensures quick, easy and safe installation

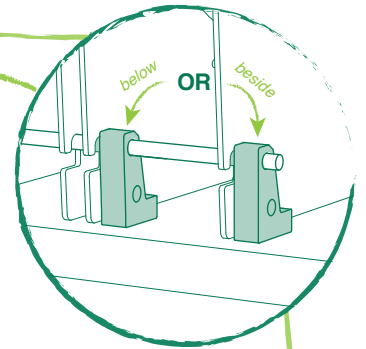
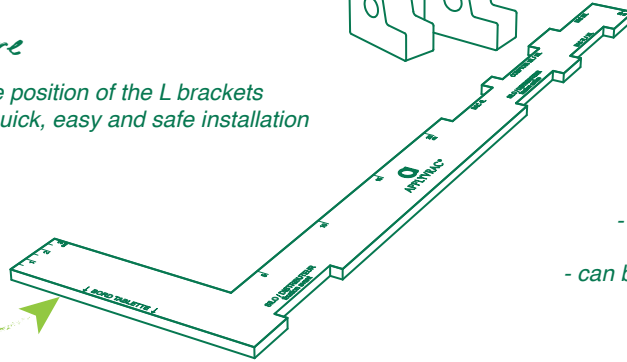

L brackets

- for threading and holding the retention bar (not provided)
- can be placed beside or below the distributors to be attached

*: Bar attachment with brackets is mandatory for gravity dispensers and specific dispensers, and optional for scoop dispensers and display cases in fixed grocery shops.

FILLING FUNNEL

Identical model for all APPLYVRAC® Eterniti® gravity dispensers

- *material* ♻️
Food-grade recyclable PET-G
(without Bisphenol A)

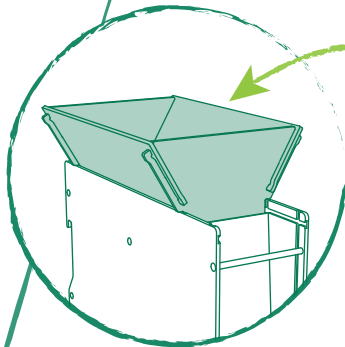

practical
for fast, safe
and clean filling

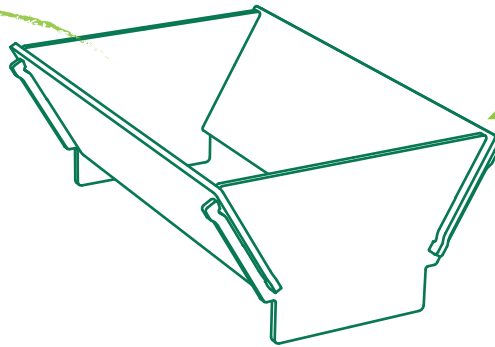

detachable

- takes up less space (delivered flat)
- easy and quick to clean

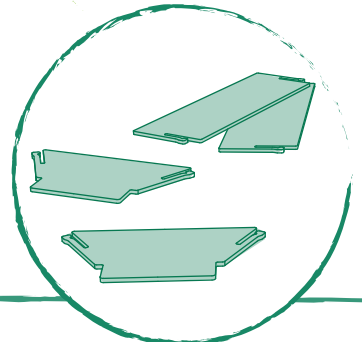

SERVING FUNNEL

Adapted to customers' small containers

- *material* ♻️
Food-grade recyclable HDPE
(without Bisphenol A)

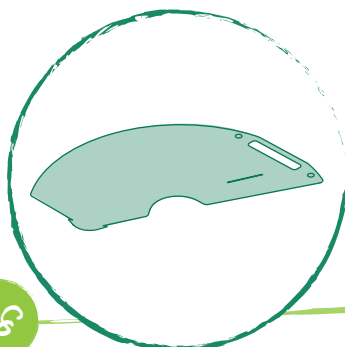

*holes for threading
a strap
(safe use)*

can be rolled-up/unrolled
- takes up less space (delivered flat)
- quick and easy to clean

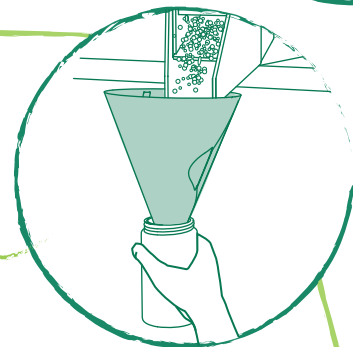

practical

- for self service (can be attached to the gravity dispenser's bag-holder)
- identical model for all Applyvrac® gravity dispensers

Some installation examples

OF THE APPLYVRAC® ETERNITI® RANGE

APPLYVRAC®
eterniti



about Applymage®



Our expertise

APPLYMAGE®, based in the Lyon region, has been designing and producing **display cases and dispensers** for various business sectors, including the health and convenience store sectors, **since 2007**.

With its products, **APPLYMAGE®** aims to **showcase its customers' products** for improved marketing.

APPLYMAGE® products are **distributed** directly or via its customers **across all five continents** in over 80 countries.

Our approach

APPLYMAGE® and its designers – who have received the "Observateur du Design" award several times – are committed to developing **eco-designed** products that are **made in France**, increasingly **innovative** and **built to last**, and which meet user needs as closely as possible.

APPLYMAGE® invests regularly and heavily in **R&D** and **Intellectual Property** to bring new innovations onto the market each year.

Applymage® Eco

APPLYMAGE® Eco, with its **Applyvrac®** and **Eterniti®** brands, focuses on developing equipment and solutions intended to improve the layout and dynamism of **retail outlets and convenience stores**, especially **organic** and **bulk grocery shops** as well as **hotels** and **homes**.



registered
& brands
trademarks
in France and abroad

OVER **15** years
of experience
38,000 Applyvrac®
in service
OVER **550** grocery
shops equipped!

